

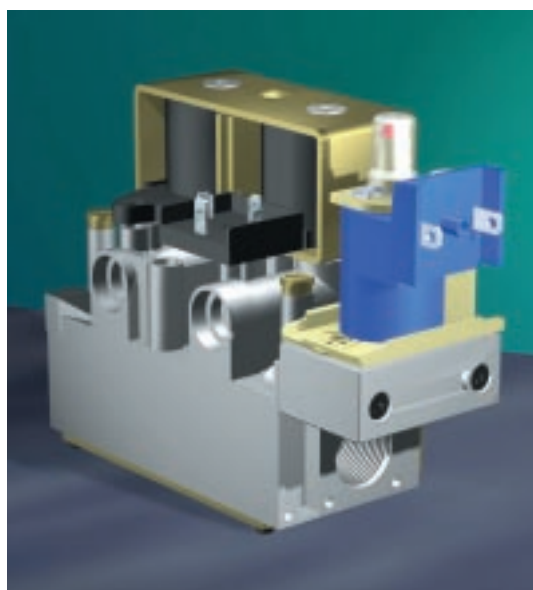

SIT Group

836 - 837 TANDEM

MULTIFUNCTIONAL GAS CONTROL



**MODULATOR FOR OUTLET GAS FLOW:
STEPPED (836 TANDEM) - CONTINUOUS (837 TANDEM)**

SERVO-CONTROLLED PRESSURE REGULATOR

ALL ADJUSTMENTS ACCESSIBLE FROM ABOVE



ELECTRICALLY MODULATED AUTOMATIC MULTIFUNCTIONAL CONTROL

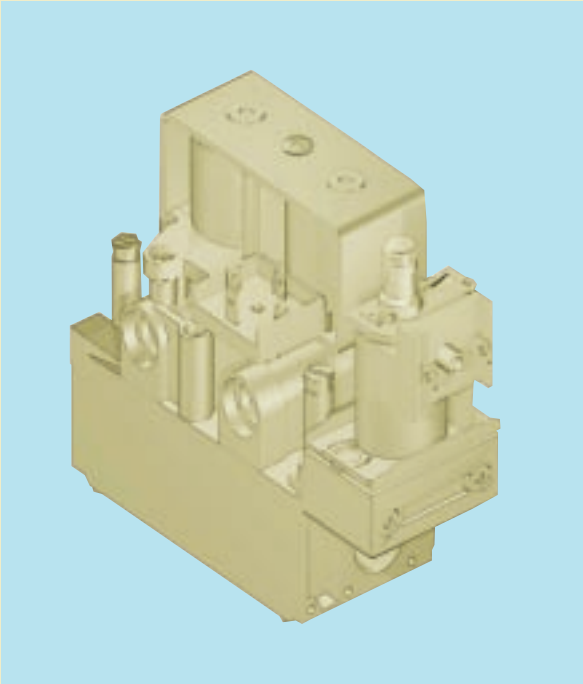

Multifunctional control with two near-silent automatic on-off valves, fitted with electrically modulated stepped (836 TANDEM) or continuous (837 TANDEM) gas flow. Servo-controlled pressure regulator.

836-837 TANDEM is suitable for appliances for catering, water heating and convector heaters, fitted with automatic ignition and flame supervision systems, which require the regulation of the gas flow as a function of the temperature.

MAIN FEATURES

Electric modulator of the gas outlet pressure: stepped (836 TANDEM) or continuous (837 TANDEM).
Two near-silent automatic shut-off valves in class B (class A on request).
Servo-controlled pressure regulator.
Pilot outlet (optional) with gas flow restrictor.
Inlet and pilot filters.
Inlet and outlet pressure test points.
Threaded gas inlet and outlet with provision for flange connection.
Connection for pressure regulator/combustion chamber compensation.

Data refer to EN 126

DESCRIPTION

- | | |
|---|---|
| <ul style="list-style-type: none"> 1 On-off solenoid valve EV1 2 Gas outlet pressure modulator 3 Adjustment screw for gas flow to the pilot 4 Inlet pressure test point 5 Outlet pressure test point | <ul style="list-style-type: none"> 6 On-off solenoid valve EV2 7 Pilot outlet 8 Main gas outlet 9 Holes (M4) for fixing flanges 10 Connection for pressure regulator / combustion chamber compensation |
|---|---|

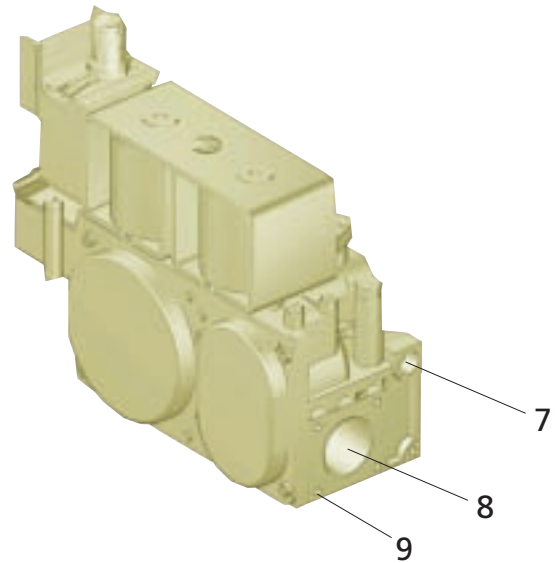
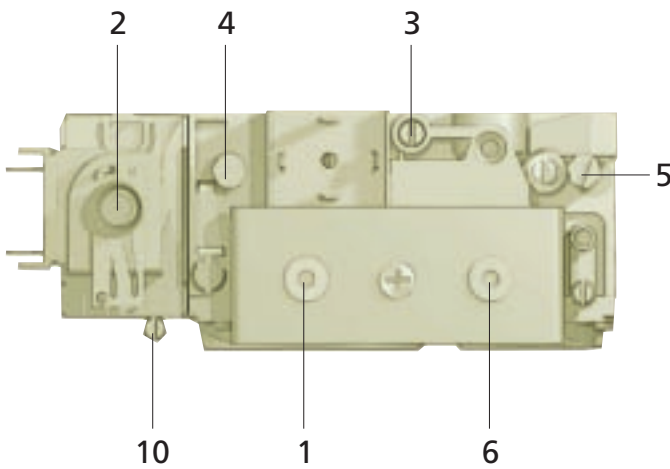

TECHNICAL DATA

- Gas connections: Rp 1/2 ISO 7
- Installation position: any position
- Gas families: I, II and III
- Maximum gas inlet pressure: 60 mbar
- Working temperature range: 0 ... 60°C (-20 ... +60°C on request)
- Pressure regulator: Class C
- Automatic solenoid valves: Class B (Class A on request)

- **836 TANDEM**
stepped modulator - outlet gas pressure setting range:
- max. pressure 7 - 50 mbar (230V version: 7 ... 37 mbar)
- min. pressure 2 - 45 mbar (230V version: 2 ... 30 mbar)

- **837 TANDEM**
continuous modulator - outlet gas pressure setting range:
2 - 20 mbar (white screw)
on request 3 - 37 mbar (red screw)
on request 7 - 50 mbar (black screw)

POWER SUPPLY

STEPPED MODULATOR (836)		CONTINUOUS MODULATOR (837)	
Voltage (rectified AC)	Consumption (mA)	Voltage (DC)	Consumption (mA)
230 V	27	220 V max	25 max
24V	270	28 V max	165 max
		16 V max	310 max

SAFETY SOLENOID VALVES

EV1 + EV2	Class A	Class B	Low Power vers.
Voltage (AC)	Consumption (mA)	Consumption (mA)	Consumption (mA)
230 V 50 Hz	80	80	-
220 V 60 Hz	-	90	-
24 V 50 Hz	900	850	500
24 V 60 Hz	-	900	600

Electrical protection rating IP54 with 150 type connectors.

Data refer to EN 126



DIMENSIONS

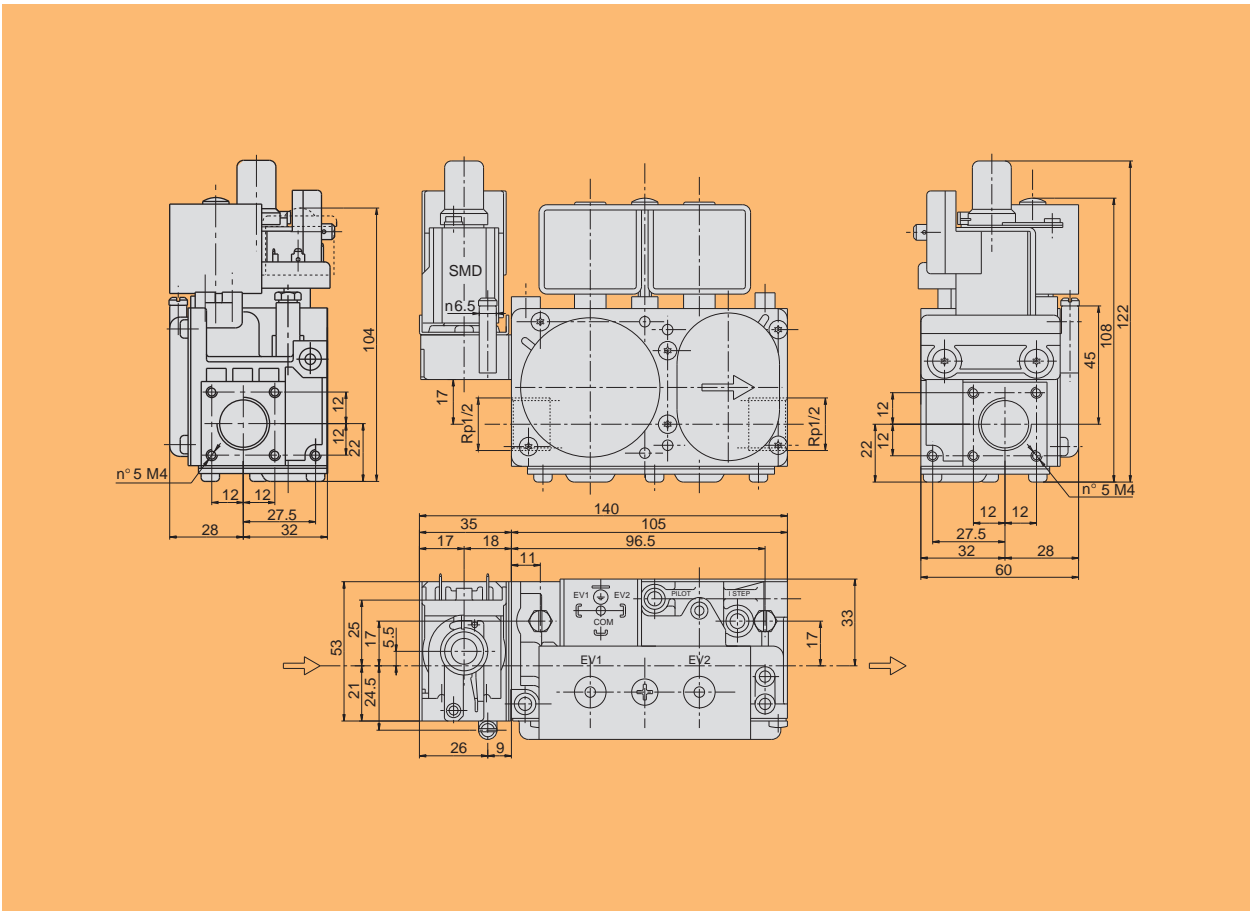

FLOW RATE AS A FUNCTION OF PRESSURE DROP

Q [m³/h d=0.6]

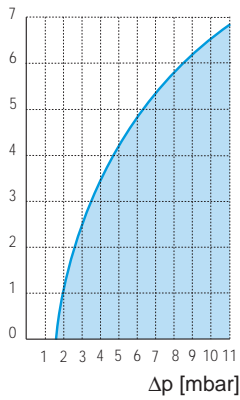

CLASS B+B

CLASS B+B

I	Family (d = 0.45)	Q = 4.8 m³/h	$\Delta p = 5$ mbar
II	Family (d = 0.6)	Q = 4.2 m³/h	$\Delta p = 5$ mbar
III	Family (d = 1.7)	Q = 2.8 kg/h	$\Delta p = 5$ mbar

OPERATION

Reading the inlet pressure

The inlet pressure can be read at the pressure test point E with or without both on-off solenoid valves energized.

Pilot burner ignition

When the automatic shut-off valve EV1 is powered, it permits the gas to supply the pilot burner outlet (applications with intermittent pilot) after passing through the inlet filter, the pilot filter and the pilot flow rate restrictor (PILOT).

Main burner ignition

When both automatic valves, EV1 and EV2, are energized, gas passage to the main burner is opened.

Outlet pressure

The outlet pressure is read at the test point A.

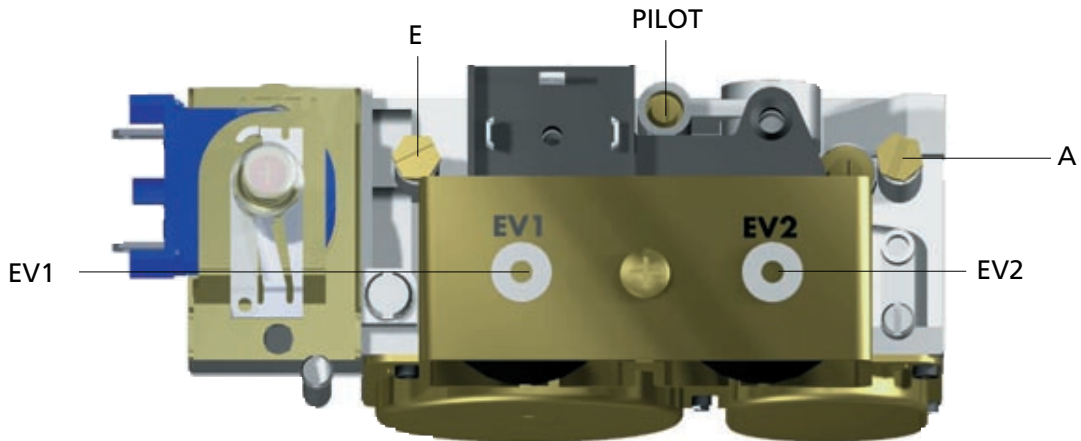

REGULATED FLOW RATE IN ACCORDANCE WITH EN 88

Q [m³/h d=0.6]

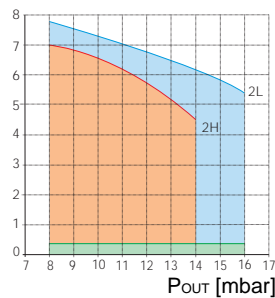

CLASS B+B

Gas type	Inlet pressure range (mbar)		
	Nominal	Max.	Min.
2H	20	25	17
2L	25	30	20

Outlet pressure tolerance +10%...-15%

837: CHARACTERISTIC CURVES OF THE CONTINUOUS MODULATOR

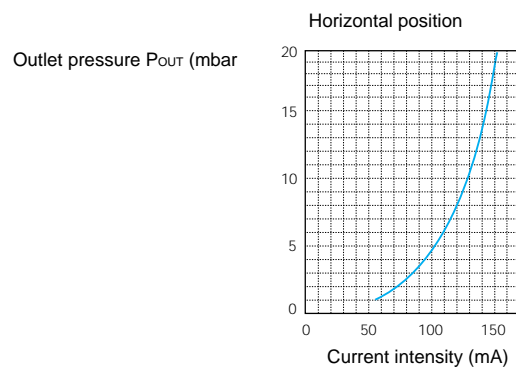
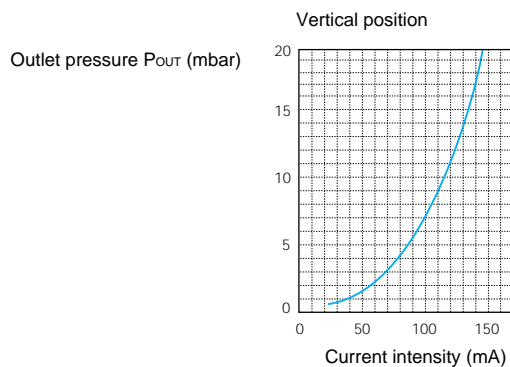

VERSION 2...20 mbar

INSTALLATION

Main gas connection

The connection is made using gas pipes with Rp 1/2 ISO 7 threading. Torque: 25 Nm. If, alternatively, flanges (available on request) are used, first screw the pipes onto the flanges and then the flanges to the valve. Recommended torque for the flange fixing screws: 3 Nm.

Connection to the pilot burner

Pipes with a 4 mm, 6 mm or 1/4 Ø can be used. Use a nut and olive of appropriate dimensions. Tighten to 7 Nm torque.

Connection to the combustion chamber

Pressure regulator / combustion chamber compensation is possible when the latter is pressurized (see figure).

Electrical connections

Use the special connectors for the connection of the mains-powered versions. To ensure that the valve is connected to the earth circuit of the appliance it is necessary for the power connector, which includes the earth terminal, to be used at all times and secured by means of the associated screw.

The 24Vac versions must be powered by means of an isolating transformer (with a very low safety voltage to EN 60742). Use terminals AMP 6.3 x 0.8 mm, DIN 46244 for the connection. Carry out the connections in accordance with the rules for the appliance.

The electrical safety cut-off devices (for example the flame supervision device, limit thermostat, and the like) must cut off the power supply to both solenoid valves.

Stepped modulator connection (836 TANDEM)

The stepped modulator must be powered by rectified voltage. Type 350 connectors with an integrated rectified circuit should be used; otherwise insert a diode bridge and a voltage limiter, appropriately dimensioned, into the circuit.

CAUTION: after making the connections, check gas tightness and electrical insulation.

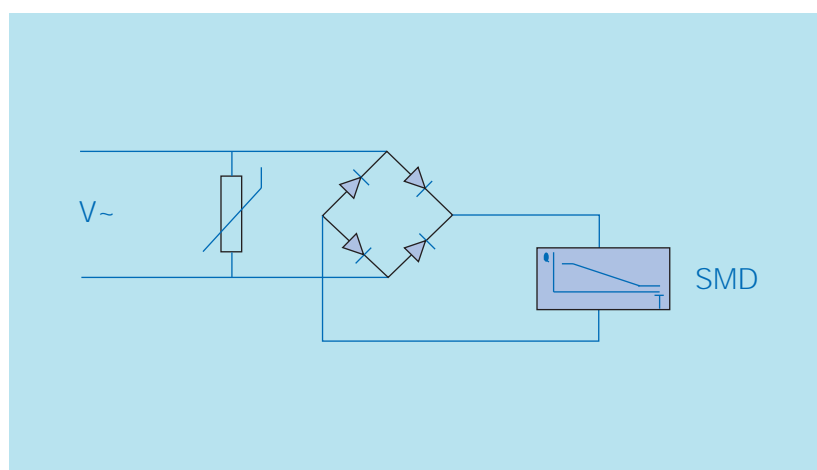

Stepped modulator connection (836 TANDEM)

Measurement of the inlet and outlet pressure

The inlet and outlet pressures of the gas can be measured by unscrewing the provided test point sealing screws.

Replace screws with 2.5 Nm torque.

Outlet pressure adjustment

Maximum pressure: power the modulator in the maximum condition - screw in the nut (B) to increase outlet pressure and screw it out to decrease it.

Minimum pressure (make this adjustment only after adjusting the maximum pressure): cut off the power supply to the modulator and, keeping the nut (B) blocked, screw in the screw (A) to increase the pressure and unscrew it to decrease it. Put back the protective plastic plug (C).

Gas flow-rate adjustment to the pilot

Screw in the associated screw to reduce the flow or unscrew it to increase flow.

Overriding gas flow-rate adjustment to the pilot

It is sufficient to screw the adjustment screw in flush and then screw it out two complete turns.

Changing the gas family or group

Check suitability for use with the gas family or group of interest.

Following the instructions given above, adjust the outlet pressure to the values indicated in the instruction booklet of the appliance.

CAUTION:

Check tightness and efficiency and seal the adjustment devices.

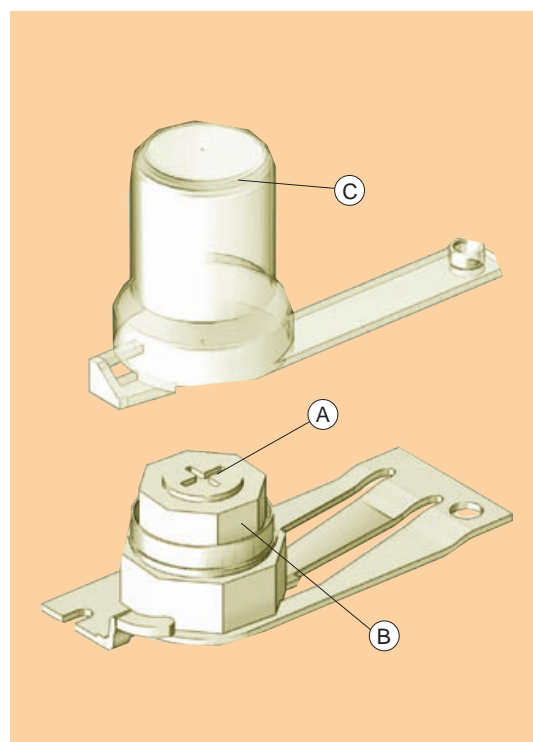

Outlet pressure adjustment

Implement the provisions in the Use and Maintenance manual - code 9.956.836, code 9.956.837 - for installation, adjustment and use.

836 - 837 TANDEM

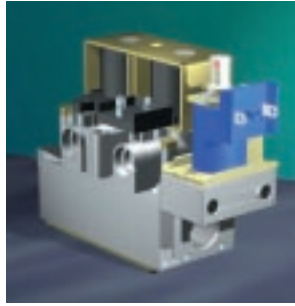

**Multifunctional control
with double solenoid valve
and electrical flow
modulator for gas
appliances fitted with
automatic ignition and
flame supervision systems
which require the
regulation of the gas flow
as a function of the
temperature.**

